



# SERIES AP 64

## SPRINGLESS ALL WELDED CHECK VALVE

Defining the new standard of safety & ultraclean

- True Springless Design, free of springs or poppets
- SS 316L VAR secondary remelt material
- 3,500 psig rated (241 bar)
- Low cracking pressure
- Reseals with minimal back pressure
- 15, 10 or 5  $\mu\text{in.}$  Ra max electropolished finish with proper surface chemistry
- DI cleaned and baked dry
- Manufactured to meet UHP requirements
- Installation and operating instructions available at [www.aptech-online.com](http://www.aptech-online.com) in the Tech Briefs section

### Operating Parameters

Source pressure	vacuum to 3500 psig (241 bar)
Cracking pressure*	3 psi (0.23 bar) differential
Maximum backpressure	3500 psig (241 bar)
Proof pressure	4,000 psig (276 bar)
Burst pressure	10,000 psig (690 bar)

\*Cracking pressure is a nominal value which may vary in specific applications due to pressure, temperature and system variables such as length of time between cracking.

### Other Parameters

Inlet & outlet connectors	1/4 in. face seal or tube weld
Flow coefficient (Cv)	0.4 max
Internal volume	0.122 in. <sup>3</sup> (2cm <sup>3</sup> )
Operating temperature	-10° to +400° F (-23° to +204°C)
Surface finish	15 $\mu\text{in.}$ (0.4 $\mu\text{m}$ ) Ra max standard 10 $\mu\text{in.}$ (0.25 $\mu\text{m}$ ) and 5 $\mu\text{in.}$ (0.13 $\mu\text{m}$ ) optional
Inboard leakage	2 x 10 <sup>-10</sup> sccs
Outboard leakage	2 x 10 <sup>-10</sup> sccs at 500 psig

### Materials

Series AP 64 S	
Wetted Parts	
Body	316L SS secondary remelt
Finish	electropolished and passivated
Seal	Fluoroelastomer / FKM (Neoprene / polychloroprene optional)

All specifications subject to change without notice.

# ULTRACLEAN TECHNOLOGY BACKED BY SERVICE AND SUPPORT

## DIMENSIONAL INFORMATION

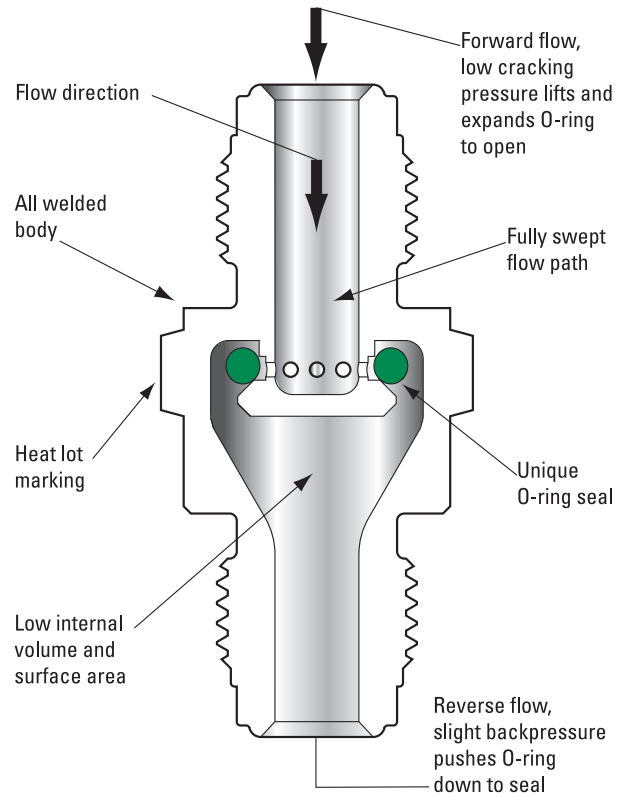
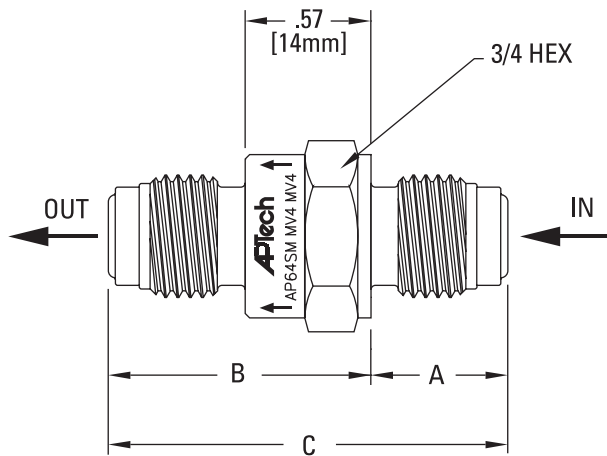

## DIMENSION CHART

Connectors (inlet x outlet)	A		B		C	
	in [±.02]	mm	in [±.02]	mm	in [±.02]	mm
MV4 x MV4	.62	16	1.19	30	1.81	46
MV4 x FV4	.62	16	1.50	38	2.12	54
FV4 x FV4	.93	24	1.50	38	2.43	62
FV4 x MV4	.93	24	1.19	30	2.12	54
TW4 x TW4	.34	9	.91	23	1.25	32

Metric dimensions are for reference only.

**CAUTION:** Product selection is the sole responsibility of the user, regardless of any recommendations or suggestions made by the factory. The user shall make selections based upon their own analysis and testing with regard to function, material compatibility and product ratings. Proper installation, operation and maintenance are also required to assure safe, trouble free performance.

## ORDERING INFORMATION

Sample Order Number		AP 64SM MV4 MV4 NP	
<b>AP 64</b>   Series	AP 64	<b>MV4 MV4</b>   Connections Inlet / Outlet	FV4 = 1/4 inch face seal female MV4 = 1/4 inch face seal male TW4 = 1/4 inch tube stub weld  Optional connections available
<b>S</b>   Material	S = Stainless steel (SS)	<b>NP</b>   Option	NP = Neoprene / polychloroprene seal*  *Nominal cracking pressure 6 psi (0.4 bar) differential
<b>M</b>   Surface Finish Options	M = 10 µin. Ra max. X = 5 µin. Ra max.		

ООО «Армада»

191036, г. Санкт-Петербург, ул. 8-я Советская, дом 26 лит. А, пом. 20-Н Тел.: +7 (812) 642-85-75 arm-lok@mail.ru, arm-lok.ru