

# SERIES AZ 37, 38 & 39

## 1/2 INCH DIAPHRAGM VALVE

Springless – manual and pneumatic (NC & NO)

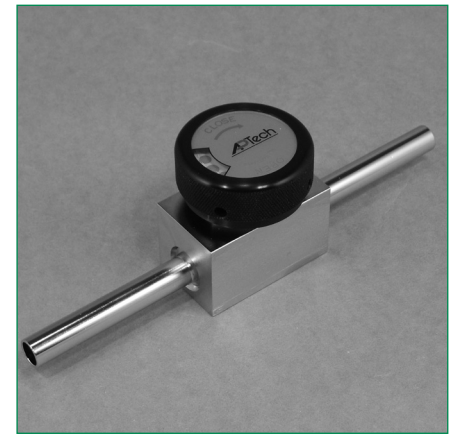

- 316L SS construction
- Operating pressure vacuum to 250 psig (17 bar)
- Machined from bar stock
- Lock out / tag out (LOTO) standard with AP 3900 manual valve
- Flow capacity 2.8 C<sub>v</sub>
- Surface finish 10 μin. Ra
- Indicating switch option for pneumatic valves AP 3700 and AP 3708
- Installation and operating instructions available at [www.aptech-online.com](http://www.aptech-online.com) in the Tech Briefs section

### Materials — wetted parts, all valves

Body	SS 316L
Finish	electropolished and passivated
Diaphragm	stainless steel 316L
Seat	PCTFE (Polyimide optional)

### Manual valves

	PSIG / BAR 250 / 17
<b>AZ 3800</b>	●
– Round knob	
– Open/closed status indicating window	
<b>AZ 3900</b>	●
– Round knob	
– Open/closed status indicating window	
– Pull, then turn to open – operational or safety feature	
– Lock out/tag out (LOTO) – integral standard feature	

### Pneumatic valve, normally closed (NC)

	PSIG / BAR 250 / 17
<b>AZ 3700</b>	●
– Switch option for remote monitoring	

### Pneumatic valve, normally open (NO)

	PSIG / BAR 250 / 17
<b>AZ 3708</b>	●
– Switch option for remote monitoring	

### Operating Parameters — all valves

Inlet pressure	vacuum to 250 psig (17 bar)
Outlet pressure	vacuum to inlet pressure
Proof pressure	150% of maximum rating
Burst pressure	300% of maximum rating

### Other Parameters — all valves

Inlet /outlet connectors	3/8, 1/2 or 3/4 inch face seal or tube weld
Flow coefficient (Cv)	2.8, X <sub>T</sub> = 1.0
Internal volume	0.76 in <sup>3</sup> (12.52 cm <sup>3</sup> )
Operating temperature	-40° to +160°F (-40° to +71°C)
Surface finish	10 μin. Ra avg (0.25 μm)
Inboard leakage	2 x 10 <sup>-10</sup> sccs
Outboard leakage	2 x 10 <sup>-9</sup> sccs He
Leakage across seat	4 x 10 <sup>-8</sup> sccs He

### Operating Parameters — pneumatic valves

Status	AZ 3700	normally closed (NC)
	AZ 3708	normally open (NO)
Actuation port		M5, side port
Actuation pressure		80 to 100 psig (5.5 to 7 bar)

All specifications subject to change without notice.

# ULTRACLEAN TECHNOLOGY BACKED BY SERVICE AND SUPPORT

DIMENSIONAL INFORMATION

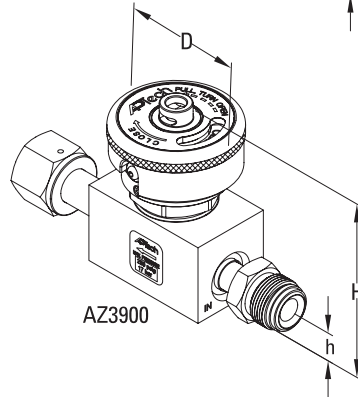
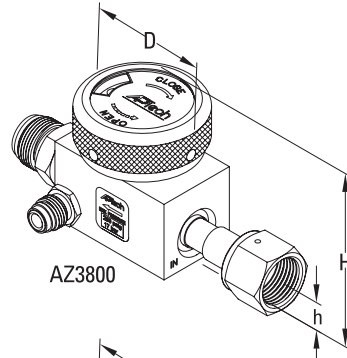
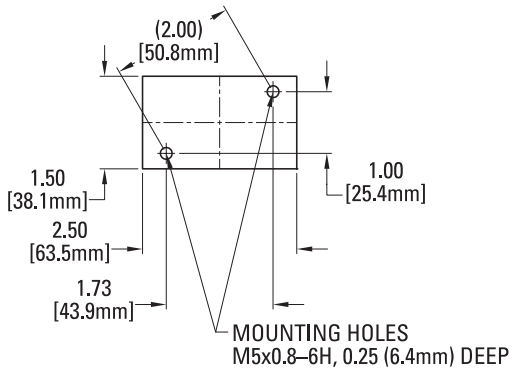
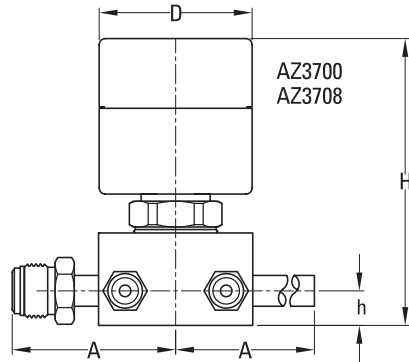
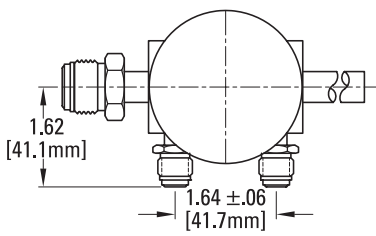

- Metric dimensions are for reference only.
- All specifications subject to change without notice.
- AZ3800 valve is shown in open position.
- AZ3900 valve is shown in closed position.

CONNECTION	A	
	inch [±.02]	mm
FV8, MV8	2.65	67.3
TW6, TW8, TW12	4.25	108
FV12, MV12	3.20	81.3

VALVE	D		H		h	
	inch	mm	inch	mm	inch	mm
AZ3700	ø2.48	63.0	4.8	122	.56	14.2
AZ3708	ø2.48	63.0	4.2	107	.56	14.2
AZ3800	ø2.25	57.2	2.6	66	.56	14.2
AZ3900	ø2.25	57.2	3.4	86	.56	14.2

**CAUTION:** Product selection is the sole responsibility of the user, regardless of any recommendations or suggestions made by the factory. The user shall make selections based upon their own analysis and testing with regard to function, material compatibility and product ratings. Proper installation, operation and maintenance are also required to assure safe, trouble free performance.

ORDERING INFORMATION

Sample Order Number

AZ 3700SM TW8 TW8 0B C

**AZ 37** | Series

AZ 37 = Air actuated  
AZ 38 = Manual  
AZ 39 = Manual, LOTO

| **Status**  
(AZ37 only)

00 = Normally closed or manual valve  
08 = Normally open

**s** | Material

S = Stainless steel (SS)

**TW8 TW8** | Connections  
Inlet / Outlet  
(main / branch)

TW6 = 3/8 inch tube stub weld  
FV8 = 1/2 inch face seal female  
MV8 = 1/2 inch face seal male  
TW8 = 1/2 inch tube stub weld  
FV12 = 3/4 inch face seal female  
MV12 = 3/4 inch face seal male  
TW12 = 3/4 inch tube stub weld

**0B** | Purge Port  
Inlet / Outlet  
(main / branch)

M = Inlet purge port  
B = Outlet purge port  
0 = No purge port

**c** | Options

VS = Polyimide Seat  
ISC = Indicator Switch, NC  
(3700 & 3708 only)\*  
ISO = Indicator Switch, NO  
(3700 & 3708 only)\*  
C = Capped Purge Port

\*Refer to operating manual for further switch information.

AP Tech has product options and variations which are not documented in data sheets. If you have a model number that is not defined by the ordering information, please consult the factory or your local representative.

ООО «Армада»

191036, г. Санкт-Петербург, ул. 8-я Советская, дом 26 лит. А, пом. 20-Н Тел.: +7 (812) 642-85-75 arm-lok@mail.ru, arm-lok.ru